



aerospace  
climate control  
electromechanical  
filtration  
fluid & gas handling  
hydraulics  
**pneumatics**  
process control  
sealing & shielding



# Man/Machine Dialogue

Push-buttons, Two-hand control units

PDE2627TCUK March 2010



ENGINEERING YOUR SUCCESS.



**Important !**

Before carrying out any service work, ensure that the valve and manifold have been vented. Remove the primary supply air hose to ensure total disconnection of the air supply before dismantling valves or blank connection blocks.



**NB !**

All technical data in this catalogue is typical only. The air quality is decisive for the valve life: see ISO 8573.



**WARNING**

FAILURE OR IMPROPER SELECTION OR IMPROPER USE OF THE PRODUCTS AND/OR SYSTEMS DESCRIBED HEREIN OR RELATED ITEMS CAN CAUSE DEATH, PERSONAL INJURY AND PROPERTY DAMAGE.

This document and other information from Parker Hannifin Corporation, its subsidiaries and authorized distributors provide product and/or system options for further investigation by users having technical expertise. It is important that you analyze all aspects of your application and review the information concerning the product or system in the current product catalog. Due to the variety of operating conditions and applications for these products or systems, the user, through its own analysis and testing, is solely responsible for making the final selection of the products and systems and assuring that all performance, safety and warning requirements of the application are met. The products described herein, including without limitation, product features, specifications, designs, availability and pricing, are subject to change by Parker Hannifin Corporation and its subsidiaries at any time without notice.

**SALE CONDITIONS**

The items described in this document are available for sale by Parker Hannifin Corporation, its subsidiaries or its authorized distributors. Any sale contract entered into by Parker will be governed by the provisions stated in Parker's standard terms and conditions of sale (copy available upon request).

## Page

### **Push button valves Ø 22**

Generalities.....	4
Spring return pushbuttons .....	4
Mushroom head pushbuttons .....	4
Selector switches.....	5
Switch bodies with operating head mounting .....	5
Additional switch valves.....	5
Electrical contact blocks .....	5
Mounting block for valves and operating heads .....	6
Operating heads .....	6 - 7
Joystick controllers .....	7
Dimensions and assembling.....	8

### **Visual indicators**

Generalities.....	9
References and dimensions .....	10

### **Two-hand control units**

Generalities.....	11
References .....	12
Dimensions .....	13

- Facia mounted operator
- 3/2 NO or NC
- Pneumatic valves combinable with electrical switches
- Modular construction (up to 3 valves per pushbutton heads)
- Wide range of actuators



### Operating and additional information

Working pressure

PXB-B3•• 1 to 9 bar  
 PXB-B4•• 1 to 10 bar

Connections

Ø4 mm straight Push-in as standard  
 Ø4 mm swivel Push-in on request  
 M5 on request

Working temperature -15 °C to +60 °C

**Flow**

(acc. to ISO 6358)

**PXB-B3••** Q<sub>max</sub>=60 NI/min  
 Q<sub>n</sub> = 30 NI/min

**PXB-B4••** Q<sub>max</sub>=240 NI/min  
 Q<sub>n</sub> = 120 NI/min

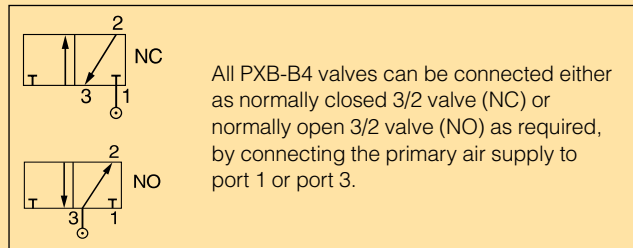

### Spring return pushbuttons - Metal head version - Ø 4 mm straight fittings

Symbol	Actuator	Return	Operating force at 6 bar, N	Flow NI/min	Weight kg	Order code
	Pushbutton Black	Spring	8,5 6,0	60 240	0,077 0,082	<b>PXB-B3111BA2</b> <b>PXB-B4131BA2</b>
	Pushbutton Green	Spring	8,5 6,0	60 240	0,077 0,082	<b>PXB-B3111BA3</b> <b>PXB-B4131BA3</b>
	Pushbutton Red	Spring	8,5 6,0	60 240	0,077 0,082	<b>PXB-B3111BA4</b> <b>PXB-B4131BA4</b>
	Pushbutton Black	Spring	16,5 14,0	60 240	0,087 0,092	<b>PXB-B3251BA2</b> <b>PXB-B4231BA2</b>

### Mushroom head pushbuttons - Metal head version - Ø 4 mm straight fittings

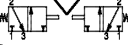
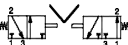
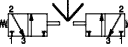
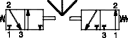
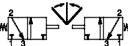

Symbol	Actuator	Return	Operating force at 6 bar, N	Flow NI/min	Weight kg	Order code
	Pushbutton Ø40 mm Black	Spring	12 6,5	60 240	0,122 0,127	<b>PXB-B3111BC2</b> <b>PXB-B4131BC2</b>
	Latching pushbutton Ø40 mm Red		48 42,5	60 240	0,125 0,127	<b>PXB-B3111BT4</b> <b>PXB-B4131BT4</b>
	Latching pushbutton Ø40 mm Red		49 43,5	60 240	0,125 0,127	<b>PXB-B3121BT4</b> <b>PXB-B4131BT4</b>

**Selector switches - Metal head version - Ø 4 mm straight fittings**

Symbol	Actuator	Return	Flow Nl/min	Weight kg	Order code
	Latching selector button 2 positions, Black		60	0,092	<b>PXB-B3111BD2</b>
			240	0,097	<b>PXB-B4131BD2</b>
	Latching selector button 2 positions, Black		60	0,102	<b>PXB-B3211BD2</b>
			240	0,107	<b>PXB-B4231BD2</b>
	Latching selector button 2 positions, Black		60	0,102	<b>PXB-B3251BD2</b>
			240	0,107	<b>PXB-B4231BD2</b>
	Latching selector button 3 positions, Black		60	0,102	<b>PXB-B3211BD3</b>
			240	0,107	<b>PXB-B4231BD3</b>
	Latching selector button 3 positions, Black		60	0,102	<b>PXB-B3251BD3</b>
			240	0,107	<b>PXB-B4231BD3</b>
	Non latching selector button with long handle 3 positions, Black	Spring	60	0,103	<b>PXB-B3211BJ5</b>
			240	0,108	<b>PXB-B4231BJ5</b>





**Switch bodies with operating metal head mounting - Ø 4 mm straight fittings**

For use with ZB4 operating heads



Symbol	Actuator	Return	Operating force at 6 bar, N	Flow Nl/min	Weight kg	Order code
	Plunger	Spring	7	60	0,048	<b>PXB-B3111B</b>
			4,5	240	0,053	<b>PXB-B4131B</b>
	Plunger	Spring	8	60	0,048	<b>PXB-B3121B</b>
			4,5	240	0,053	<b>PXB-B4131B</b>

**Additional switch valves - Ø 4 mm straight fittings**

For use with ZB4 and ZB5 operating heads and mounting blocks

Symbol	Actuator	Return	Operating force at 6 bar, N	Flow Nl/min	Weight kg	Order code
	Plunger Straight connection	Spring	7	60	0,010	<b>PXB-B3911</b>
			4,5	240	0,015	<b>PXB-B4931</b>
	Plunger Straight connection	Spring	8	60	0,010	<b>PXB-B3921</b>
			4,5	240	0,015	<b>PXB-B4931</b>
	Plunger Swivel connection	Spring	7	60	0,015	<b>PXB-B3912</b>
			4,5	240	0,021	<b>PXB-B4932</b>
	Plunger Swivel connection	Spring	8	60	0,015	<b>PXB-B3922</b>
			4,5	240	0,021	<b>PXB-B4932</b>

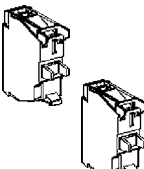
**Electrical contact blocks**

Connections	Type of contact	Weight kg	Order code
 Can be combined with pneumatic valve blocks, enabling pneumatic and electric signals to be provided from a single control unit.	Normally open (NO) 	0,011	<b>ZBE-101</b>
	Normally closed (NC) 	0,011	<b>ZBE-102</b>

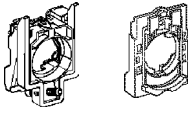

## Mounting block for valves and operating heads

Description	For Metal head ZB4		For Plastic head ZB5	
	Weight kg	Order code	Weight kg	Order code
 <p><b>Mounting block for valves and operating heads:</b> to make up a complete push button with one operating head and switch valves.</p>	0,038	<b>ZB4-BZ009</b>	0,006	<b>ZB5-AZ009</b>

## Operating heads

For use with PXB-B3. and PXB-B4. switch bodies

### Spring return pushbuttons

Description	Colour	Metal head		Plastic Head	
		Weight kg	Order code	Weight kg	Order code
 <p>Flush</p>	Black	0,029	<b>ZB4-BA2</b>	0,018	<b>ZB5-AA2</b>
	Green	0,029	<b>ZB4-BA3</b>	0,018	<b>ZB5-AA3</b>
	Red	0,029	<b>ZB4-BA4</b>	0,018	<b>ZB5-AA4</b>
	6 color caps	0,029	<b>ZB4-BA9</b>	0,018	<b>ZB5-AA9</b>
 <p>Projecting</p>	Black	0,030	<b>ZB4-BL2</b>	0,019	<b>ZB5-AL2</b>
	Green	0,030	<b>ZB4-BL3</b>	0,019	<b>ZB5-AL3</b>
	Red	0,030	<b>ZB4-BL4</b>	0,019	<b>ZB5-AL4</b>
 <p>Flush booted</p>	Black	0,034	<b>ZB4-BP2</b>		



### Push/push pushbuttons

Description	Colour	Metal head	
		Weight kg	Order code
 <p>Flush</p>	Black	0,029	<b>ZB4-BH02</b>
	Green	0,029	<b>ZB4-BH03</b>
	Red	0,029	<b>ZB4-BH04</b>

### Double headed spring return pushbuttons

Description	Colour Marking	Metal head	
		Weight kg	Order code
 <p>Flush</p>	Green/Red I/O	0,047	<b>ZB4-BA7341</b>

### Mushroom head pushbuttons

Description	Function	Colour	Metal head		Plastic Head	
			Weight kg	Order code	Weight kg	Order code
 <p>Ø40 mm Mushroom head</p>	Spring return	Black	0,074	<b>ZB4-BC2</b>		
		Green	0,074	<b>ZB4-BC3</b>		
		Red	0,074	<b>ZB4-BC4</b>		
	Latching push-pull	Red	0,077	<b>ZB4-BT4</b>		
 <p>Ø60 mm Mushroom head</p>	Spring return	Black	0,093	<b>ZB4-BR2</b>		
 <p>Ø40 mm Mushroom head</p>	Latching Turn to release	Red	0,070	<b>ZB4-BS54</b>	0,044	<b>ZB5-AS54</b>
	Latching Release by Ronis key N°455	Red	0,070	<b>ZB4-BS14</b>		

## Selector switches

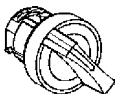
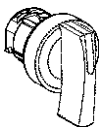
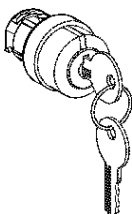
	Description	Function	Metal head		Plastic Head				
			Weight kg	Order code	Weight kg	Order code			
	Standard, black handle	2 positions	Stay put	0,044	<b>ZB4-BD2</b>	0,024	<b>ZB5-AD2</b>		
		3 positions	Stay put	0,044	<b>ZB4-BD3</b>	0,024	<b>ZB5-AD3</b>		
		3 spring return to centre		0,044	<b>ZB4-BD5</b>	0,024	<b>ZB5-AD5</b>		
	Long black handle	2 positions	Stay put	0,045	<b>ZB4-BJ2</b>				
		3 positions	Stay put	0,045	<b>ZB4-BJ3</b>				
			Spring return to centre	0,045	<b>ZB4-BJ5</b>				
			1 spring return from left to centre	0,045	<b>ZB4-BJ7</b>				
	Description	Function	Key with drawal	Weight kg	Order code				
					<b>Key operated</b>	2 stay put	Left	0,069	<b>ZB4-BG2</b>
					(Ronis key N° 455)	positions	Left and right	0,069	<b>ZB4-BG4</b>

## Tools

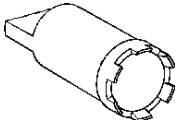
	Description	Weight kg	Order code
	ZB5 head nut tool	0,160	<b>ZB5-AZ905</b>

**Dimensions**

**PXB-B3**

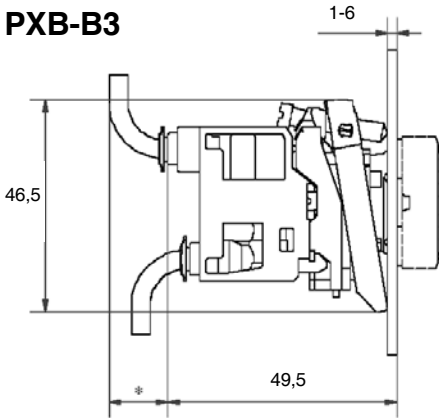

Body width 30 mm  
 \* With 2 x 4 mm tube = 10  
 With 2,7 x 4 mm tube = 15

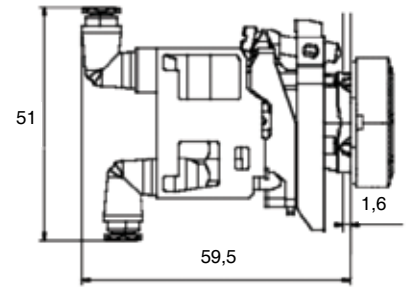
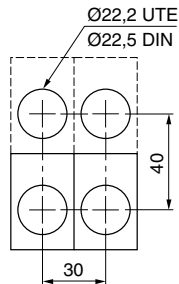

**PXB-B4**

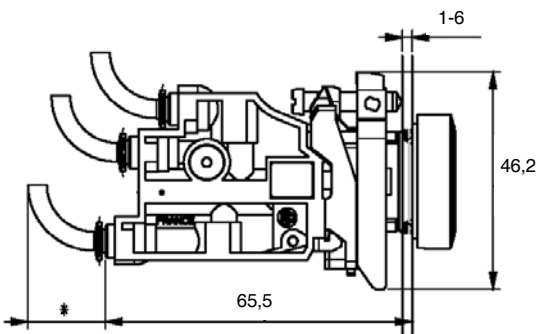

Body width 30 mm  
 \* With 2 x 4 mm tube = 10  
 With 2,7 x 4 mm tube = 15

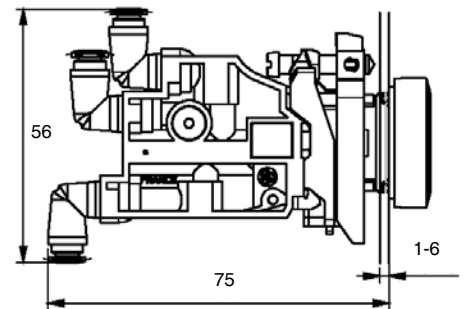

**Assembling of PXB-B3. and PXB-B4. valves on mounting block**

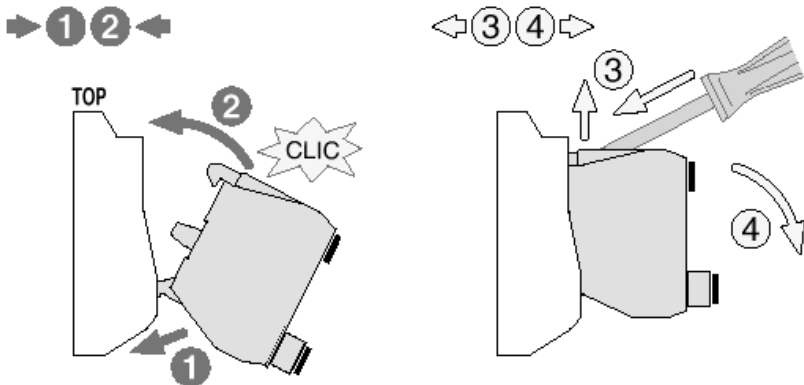

**Assembling of PXB-B3. and PXB-B4. valves on the back of the electrical contact**

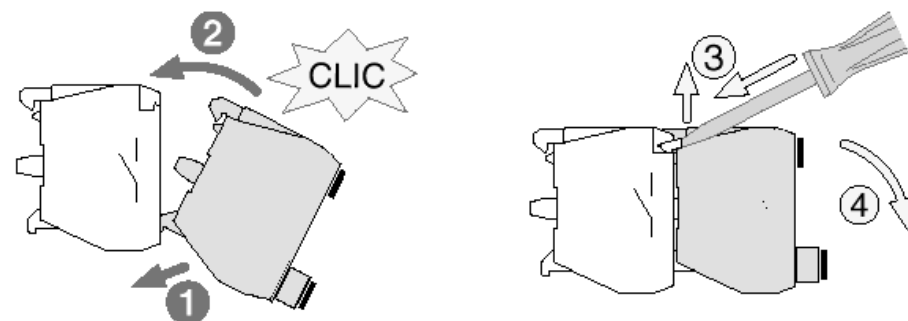



- Lightning fast response
- Simple long life mechanism
- Very high contrast
- All around visibility
- One single pipe connection
- Effective aid to diagnostics



### Operating information

Working pressure 1-8 bar  
 Working temperature -15 °C to +60 °C

### Options and additional information

Connections Ø4 mm straight Push-in as standard

### Order key

**P X V - F 1 2 1 3 - E X**

	Ø
<b>F1</b>	22 mm
<b>M1</b>	30 mm

	Colour, actuated
<b>1</b>	White
<b>2</b>	Black
<b>3</b>	Green
<b>4</b>	Red
<b>5</b>	Yellow
<b>6</b>	Blue

	Connection
<b>1</b>	Ø4 mm Push-in
<b>5</b>	M5

	Colour, unactuated
<b>1</b>	White
<b>2</b>	Black
<b>3</b>	Green
<b>4</b>	Red
<b>5</b>	Yellow
<b>6</b>	Blue

**ATEX Version**  
\*

\*  
See :  
PDE2584TCUK-ev

## Ø22 mm Visual Indicators

Black plastic bezel  
In the actuated mode

Symbol	Colour *	Weight kg	Order code
	Green	0,080	<b>PXV-F131</b>
	Red	0,080	<b>PXV-F141</b>
	Yellow	0,080	<b>PXV-F151</b>
	Blue	0,080	<b>PXV-F161</b>
	White	0,080	<b>PXV-F111</b>

## Ø22 mm Visual Indicators

Black plastic bezel  
In the unactuated mode

Symbol	Colour *	Weight kg	Order code
	Green	0,080	<b>PXV-F1213</b>
	Red	0,080	<b>PXV-F1214</b>
	Yellow	0,080	<b>PXV-F1215</b>
	Blue	0,080	<b>PXV-F1216</b>
	White	0,080	<b>PXV-F1211</b>

\* The pneumatic indicators are black in one position and coloured in the other.  
The coloured position corresponds either to the presence of pressure (actuated mode)  
or the absence of pressure (unactuated mode). For two different colours on the  
same indicator, please consult Technical Sales Department.

\*\* Visual indicators Ø 30 mm on request.

## Dimensions

### Ø22 mm visual indicators

PXV-F1••

Minimum distance between centres

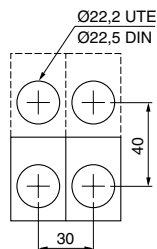
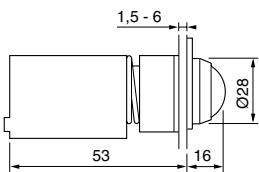

- Ergonomical design
- Easy to install
- Robust enclosure and rigid guards
- Meet requirements for protection against accidental operation and tempering
- Conforms to the EN574 and EN954-1 requirements



## Specification

### Material

Valve body	High grade polymer
Seals	Nitrile, NBR
Enclosure	High grade polymer or metal

## Operating information

Working pressure	3-8 bar
Working temperature	-5 °C to +60 °C

## European standard definition

EN 292-1 safety of machinery part 1

Extract : two-hand control device

A device which requires at least simultaneous actuation by use of both hands in order to initiate and to maintain, whilst a hazardous condition exists, any operation of a machine thus affording a measure of protection only for the person who actuates.

## Conformity to standard

Conformity to the recommendation about health and security  
n° 89/392/CEE revised.

## Ce Type examination Certificate

The two-hand control devices, here after, conform to models that have obtained CE Type test Certificate by the CETIM.

Description	Function	Order code	N°	CE Type examination Certificate			Cat
Control module	Logic unit	PXP-A11	N°	526	5136	520 02 10 2705	III A
Two-hand control device polyester enclosure	Single control	PXP-C111	N°	526	5136	520 02 10 2701	III A
Two-hand control device polyester enclosure	Dual control	PXP-D121	N°	526	5136	520 02 10 2702	III B
Two-hand control device metal enclosure	Single control	PXP-S111	N°	526	5136	520 02 10 2703	III A
Two-hand control device metal enclosure	Dual control	PXP-S121	N°	526	5136	520 02 10 2704	III B

## Control module only

Symbol	Connections	Weight kg	Order code
	Ø4 mm Push-in	0,250	<b>PXP-A11</b>

## Complete units

Polyester enclosure, with two mushrooms head pushbuttons and control module(s)

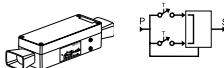
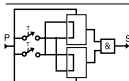
Symbol	Connections	Number of control modules	Weight kg	Order code
	Ø4 mm Push-in	1	1,000	<b>PXP-C111</b>
	Ø4 mm Push-in	2 **	1,000	<b>PXP-D121</b>

## Complete units

Metal enclosure, with two Ø 60 push buttons with protective guards and control module(s)

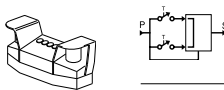
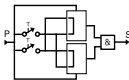
Symbol	Connections	Number of control modules	Weight kg	Order code
	Push-in Ø6 mm for supply Ø4 mm for output	1	4,200	<b>PXP-S111</b>
	Push-in Ø6 mm for supply Ø4 mm for output	2 **	4,400	<b>PXP-S121</b>

## Spare parts for two-hand control units

Description	Base component	Weight kg	Order code
1 guard for two-hand control	PXP-C111 PXP-D121	0,050	<b>PPR-L15</b>

\* These units are indispensable for ensuring that both operator's hands are occupied for reasons of safety. Both push-buttons must be operated simultaneously to produce an output signal.

\*\* Conforming to french standard NFE 09-036 " Pneumatic synchronous two-hand controls".

**Dimensions, two-hand control unit, PXP Series**

All dimensions in mm unless otherwise stated

**PXP-A11**

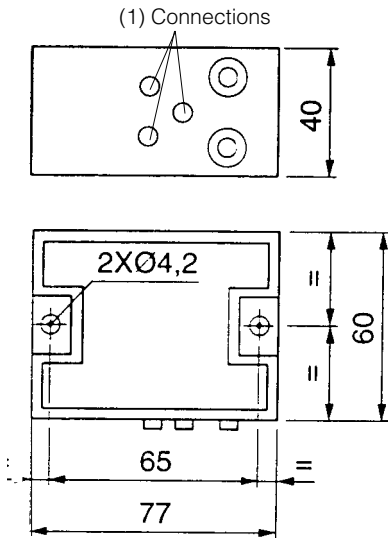

- (2) Pressure supply orifice Ø 4 mm (push-in)
- (3) Output signal orifice Ø 4 mm (push-in)

**PXPC-111 and PXP-D121**

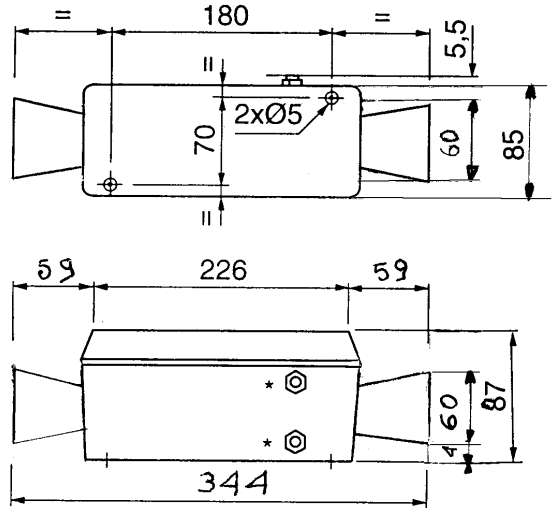

**PXP-S111 and PXP-S121**

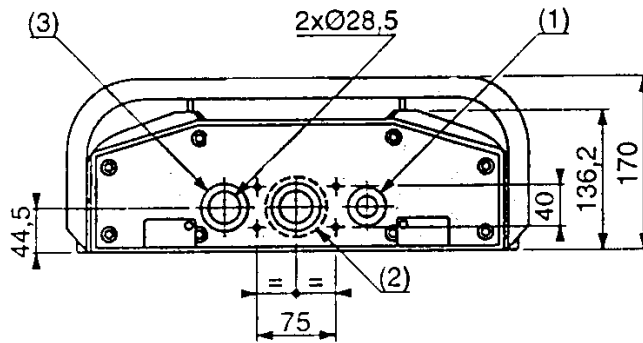

- (1) 1 hole for cable gland PG13
- (2) Pressure supply orifice Ø 4 mm (push-in)
- (3) Output signal orifice Ø 4 mm (push-in)





# Parker Worldwide

**AE – UAE**, Dubai  
Tel: +971 4 8127100  
parker.me@parker.com

**AR – Argentina**, Buenos Aires  
Tel: +54 3327 44 4129

**AT – Austria**, Wiener Neustadt  
Tel: +43 (0)2622 23501-0  
parker.austria@parker.com

**AT – Eastern Europe**,  
Wiener Neustadt  
Tel: +43 (0)2622 23501 900  
parker.easteurope@parker.com

**AU – Australia**, Castle Hill  
Tel: +61 (0)2-9634 7777

**AZ – Azerbaijan**, Baku  
Tel: +994 50 2233 458  
parker.azerbaijan@parker.com

**BE/LU – Belgium**, Nivelles  
Tel: +32 (0)67 280 900  
parker.belgium@parker.com

**BR – Brazil**, Cachoeirinha RS  
Tel: +55 51 3470 9144

**BY – Belarus**, Minsk  
Tel: +375 17 209 9399  
parker.belarus@parker.com

**CA – Canada**, Milton, Ontario  
Tel: +1 905 693 3000

**CH – Switzerland**, Etoy  
Tel: +41 (0) 21 821 02 30  
parker.switzerland@parker.com

**CL – Chile**, Santiago  
Tel: +56 2 623 1216

**CN – China**, Shanghai  
Tel: +86 21 2899 5000

**CZ – Czech Republic**, Klecany  
Tel: +420 284 083 111  
parker.czechrepublic@parker.com

**DE – Germany**, Kaarst  
Tel: +49 (0)2131 4016 0  
parker.germany@parker.com

**DK – Denmark**, Ballerup  
Tel: +45 43 56 04 00  
parker.denmark@parker.com

**ES – Spain**, Madrid  
Tel: +34 902 330 001  
parker.spain@parker.com

**FI – Finland**, Vantaa  
Tel: +358 (0)20 753 2500  
parker.finland@parker.com

**FR – France**, Contamine s/Arve  
Tel: +33 (0)4 50 25 80 25  
parker.france@parker.com

**GR – Greece**, Athens  
Tel: +30 210 933 6450  
parker.greece@parker.com

**HK – Hong Kong**  
Tel: +852 2428 8008

**HU – Hungary**, Budapest  
Tel: +36 1 220 4155  
parker.hungary@parker.com

**IE – Ireland**, Dublin  
Tel: +353 (0)1 466 6370  
parker.ireland@parker.com

**IN – India**, Mumbai  
Tel: +91 22 6513 7081-85

**IT – Italy**, Corsico (MI)  
Tel: +39 02 45 19 21  
parker.italy@parker.com

**JP – Japan**, Tokyo  
Tel: +81 (0)3 6408 3901

**KR – South Korea**, Seoul  
Tel: +82 2 559 0400

**KZ – Kazakhstan**, Almaty  
Tel: +7 7272 505 800  
parker.easteurope@parker.com

**LV – Latvia**, Riga  
Tel: +371 6 745 2601  
parker.latvia@parker.com

**MX – Mexico**, Apodaca  
Tel: +52 81 8156 6000

**MY – Malaysia**, Shah Alam  
Tel: +60 3 7849 0800

**NL – The Netherlands**,  
Oldenzaal  
Tel: +31 (0)541 585 000  
parker.nl@parker.com

**NO – Norway**, Ski  
Tel: +47 64 91 10 00  
parker.norway@parker.com

**NZ – New Zealand**, Mt Wellington  
Tel: +64 9 574 1744

**PL – Poland**, Warsaw  
Tel: +48 (0)22 573 24 00  
parker.poland@parker.com

**PT – Portugal**, Leca da Palmeira  
Tel: +351 22 999 7360  
parker.portugal@parker.com

**RO – Romania**, Bucharest  
Tel: +40 21 252 1382  
parker.romania@parker.com

**RU – Russia**, Moscow  
Tel: +7 495 645-2156  
parker.russia@parker.com

**SE – Sweden**, Spånga  
Tel: +46 (0)8 59 79 50 00  
parker.sweden@parker.com

**SG – Singapore**  
Tel: +65 6887 6300

**SK – Slovakia**, Banská Bystrica  
Tel: +421 484 162 252  
parker.slovakia@parker.com

**SL – Slovenia**, Novo Mesto  
Tel: +386 7 337 6650  
parker.slovenia@parker.com

**TH – Thailand**, Bangkok  
Tel: +662 717 8140

**TR – Turkey**, Istanbul  
Tel: +90 216 4997081  
parker.turkey@parker.com

**TW – Taiwan**, Taipei  
Tel: +886 2 2298 8987

**UA – Ukraine**, Kiev  
Tel: +380 44 494 2731  
parker.ukraine@parker.com

**UK – United Kingdom**,  
Warwick  
Tel: +44 (0)1926 317 878  
parker.uk@parker.com

**US – USA**, Cleveland  
Tel: +1 216 896 3000

**VE – Venezuela**, Caracas  
Tel: +58 212 238 5422

**ZA – South Africa**,  
Kempton Park  
Tel: +27 (0)11 961 0700  
parker.southafrica@parker.com

European Product Information Centre  
Free phone: 00 800 27 27 5374  
(from AT, BE, CH, CZ, DE, EE, ES, FI, FR, IE,  
IL, IS, IT, LU, MT, NL, NO, PT, SE, SK, UK)

